

**Bumax is Bufab's registered trademark, known as the strongest stainless steel fastener in the world.**

Bumax is manufactured in Bufab's own plants in Sweden and meets the requirements of high demanding customers when it comes to quality, corrosion resistance, high strength, fatigue strength, traceability and heat resistance. We deliver safety and reliability.

Some of the products in the Bumax family are completely unique that cannot be found anywhere else on the market. All products have full traceability (3.1 certificates available for each item) and are sourced solely from premium European stainless steel manufacturers according to rigid specifications.

**Bumax Lock is the Lock nut that stays locked – even when you would expect it to shake loose. It's simple yet ingenious thread profile enables the Bumax Lock to remain tight where other lock nuts fall down on the job. Bumax Lock is easy to fit and remove. It is an all-metal design, made of 316L high Mo premium steel as standard but other steel grades can be offered on request.**

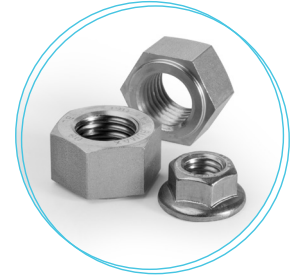

## What makes **Bumax Lock** different from conventional lock nuts?

When a bolt fails, the fracture usually occurs at the contact face of the nut. When a conventional nut is used, high stress concentrations occurs at the first engagement thread.

**Fig1.** Bumax Lock thread design

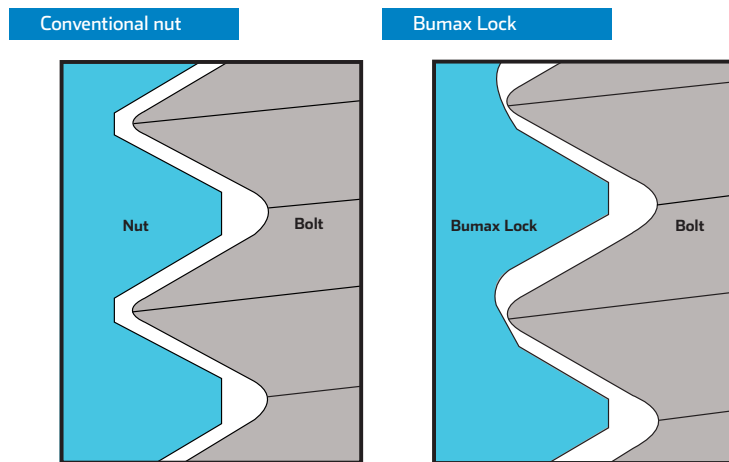

The secret of Bumax Lock lies in the thread profile itself. The angle of the root of the thread is larger and forms a wedge-shaped surface. When the nut is fitted and the torque is applied, the bolt thread bears against this flat surface. Metal to metal contact is achieved, with no gaps, no movement and no play. In short, the nut is locked. Bumax Lock thread profile locks and distributes the preload along the entire length of the thread.

Bumax Lock is made of the same steel as Bumax 88, a premium 316L high Molybdenum grade with excellent corrosion resistance. More information can be found in Bumax 88/109 datasheet. Other grades can be offered on request, such as Duplex or Super Duplex.

**Table 1.** Bumax Lock steel standard

Grades	EN ISO 3506 <sup>1)</sup>	EN	ASTM
Bumax Lock	A4	1.4432, 1.4436, 1.4435	316L high Mo

<sup>1)</sup> EN ISO 3506: Mechanical properties of corrosion-resistant stainless steel fasteners

**Table 2.** Difference in chemical composition between standard A4 and Bumax Lock

Steel grade	Chemical composition, weight-%							
	C	Si	P	S	Cr	Mo	Ni	Cu
A4 standard	max 0.08 <sup>1)</sup>	max 1	max 0.045	max 0.03	16-18.5	2 - 3	10 - 15	max 4
Bumax Lock	max 0.03	max 0.8	max 0.04	max 0.015	min 16.5	min 2.5	min 11	max 0.6

<sup>1)</sup> At the discretion of the manufacturer, the carbon content may be higher up to 0.12%



# LOCKS MORE RELIABLY

The load distribution is improved due to the fact that the Bumax Lock thread locks and distributes the preload. This in turn, increases the strength of the joint, especially in soft materials such as Aluminum Fig 2. Bumax Lock offers better protection against the nut working loose. Fig 3 shows the comparative test result between a standard nut, a metal lock nut and Bumax Lock on Junkers test equipment. All nuts are size M8 and has been preloaded to 15 kN. Bumax Lock’s locking performance is maintained even at very low preloads, can be as low as 25 % of yield strength.

Fig2. Load distribution

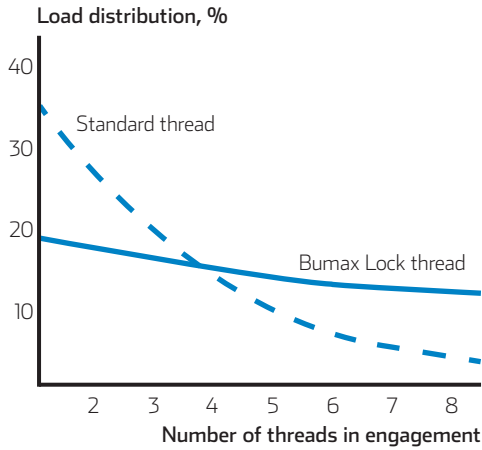
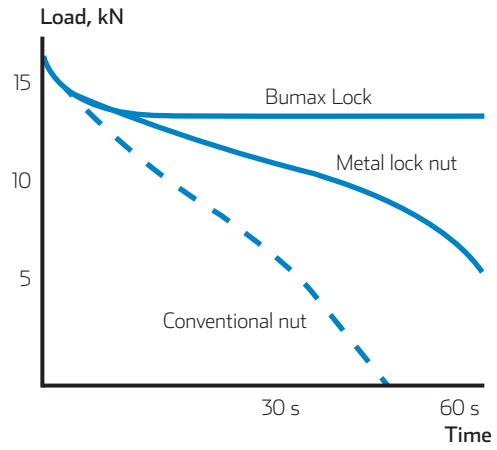

Fig3. Junker test



## EASY to fit and remove

Due to the design of the Bumax Lock thread, the nut will not lock until tightened sufficiently hard to encounter resistance. In other words, apart from being easy to fit, the design offers a low In-Place Cost. A power tool may be used for fitting. Bumax Lock is coated with our special wax, to guarantee a low friction and a trouble-free assembly.

The Bumax Lock nut locks in one direction and is designed to make it obvious how it should be fitted, with the collar or flange in contact with the bolted assembly.

The nut can be locked and unlocked up to 10 times, without losing its

function. However we recommend that the screw is changed after each unlocking.

Furthermore, since Bumax Lock is made of premium 316L high Mo steel and is an all-metal nut, it may be used for relatively high surface temperature up to approximately 300°C.

The standard range of sizes is M6-M24 however other sizes and materials such as Duplex or Super Duplex can be offered on request. Contact your local Bumax Sales representative or visit [www.bumax.se](http://www.bumax.se) for more information.

Table 3. Standard range on stock products

	Thread d	Pitch of thread	s Max.	m Max.	e min	dc-max.	Strength classification
<b>Flange</b>	M6	1	10	6	11.05	14.2	
	M8	1.25	13	8	14.38	17.9	80
	M10	1.5	15	10	16.64	21.8	80
	M12	1.75	18	12	20.03	26.0	80
<b>Collar</b>	M12	1.75	18	12	20.03		80
	M16	2	24	16	26.75		80
	M20	2.5	30	20	32.95		80

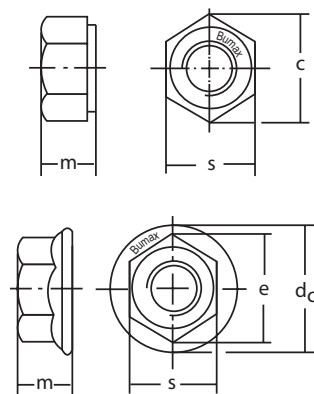

Disclaimer: The information contained in this data sheet is for guidance only and summarizes Bufab best knowledge and considered accurate as of the version date. Since the use of Bumax products is not within the control of Bufab it is the user’s obligation to determine the suitability of the product for its intended application and assumes all risk and liability for its safe use.